



Cantilever Extra Heavy Duty Installation Manual



AMERICANSURPLUS INC



1 Noyes Ave. East Providence , RI

Phone: (401) 434-4355
Contact your Salesperson.



QUESTIONS? JUST ASK!
CALL OUR SALES TEAM AT
(866) 989-7176
FOR A FREE CONSULTATION!

WWW.AMERICANSURPLUS.COM

Page 1 of 6

Our customers say **Excellent** ★★★★★ 4.9 out of 5 based on 233 reviews ★ Trustpilot



Table of Content

Introduction	Page 1
Content	Page 2
Parts list and recommended tool list	Page 3
Column and Base layout	Page 4
Arm installation	Page 5
X-Brace Installation	Page 6

Introduction

These Installations Instructions are made Available to assist in assembly of the ASI Cantilever.

Including with each shipment:

Packing List
Cantilever Layout
Instruction on Build

STEP 1:

Before Starting assembly, carefully read the instructions. Make sure you have all the necessary tools and parts laid out in front of you. It's helpful to organize the components in a logical order to streamline the process. Take your time to understand each step fully before proceeding, and don't hesitate to consult the instructions again if you encounter any difficulties.

STEP 2:

Check the packing against the material received to ensure all parts are included and are not damaged. Carefully follow any assembly instructions provided, and use the recommended tools to avoid damaging any components. If you encounter any difficulties during assembly, don't hesitate to seek assistance from customer support or refer to a professional. Properly assembled, the product should meet all specified standards and provide reliable performance for its intended use.

Phone: (401) 434-4355
Contact Your Sale Person.

Call: Monday-Thursday 8 AM to 4:30 PM & Friday 8 AM to 11 AM for free support.

American Surplus Inc. does not bear any responsibility for installation guides and manuals. While we provide products and assistance, it is the customer's responsibility to ensure the safe and proper installation of the product.

We strongly recommend that customers consult with qualified professionals if they are unsure about any aspect of the installation process. Proper installation is crucial for the safety and performance of the product, and neglecting this responsibility could lead to damage or injury.

Thank you for choosing American Surplus Inc. we appreciate your business.



QUESTIONS? JUST ASK!
CALL OUR SALES TEAM AT
(866) 989-7176
FOR A FREE CONSULTATION!

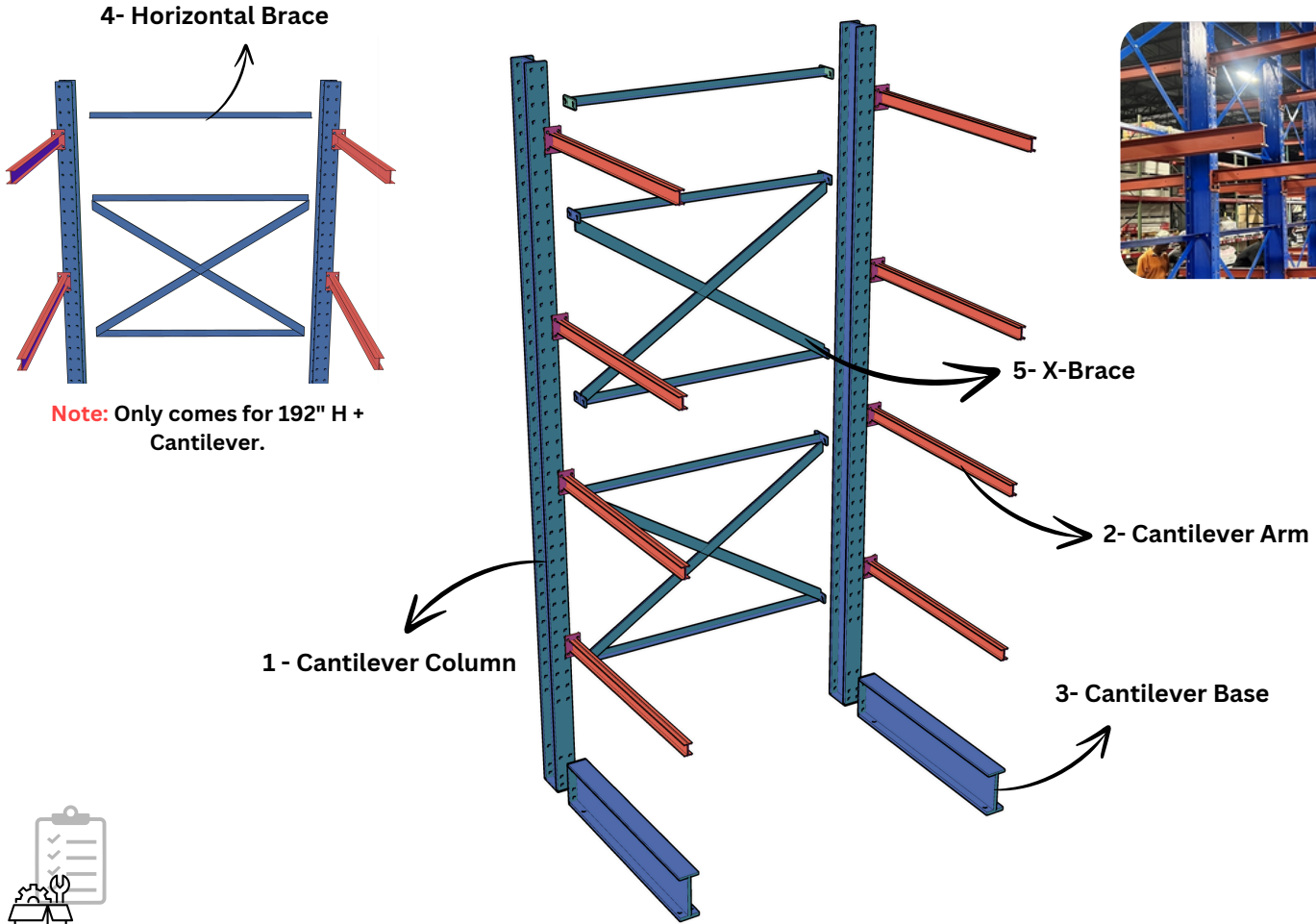

Also Includes :

Grade 5 Bolt -
(For arms and base)

3/4" Grade 5 Nut -
(For arms and base)

Long Bolt: M20*340 + Nuts M20
(For base)

1/2" - 1-1/2" Flat & Lock Washer
(For Bracing)

M12 5/8" x 4-3/8" Floor Anchors
(If Purchased)

Parts List

Cantilever Column	1
Cantilever Base	2
X-Brace	3
Horizontal Brace (192" Only)	4
Cantilever Arms	5

Tool List Recommended

- 1- Electric Impact Wrench
- 2-Straight Line Laser or Chalk Line
- 3-Black Marker
- 4-Socket Wrenches
- 5-Impact Sockets
- 6-Air Compressor



Layout and Preparation

Layout and Preparation It is very important that all measurements are checked twice before assembling or cutting any materials.

STEP 1

Clean the area by removing all debris and objects that might interfere with the assembly of your Cantilever.

STEP 2

Lay out the rack footprint on the floor. Snap a down-aisle chalk line defining the main aisle, and snap cross-aisle chalk lines defining the edge of each cantilever baseline. (If you have more than Starter make additional chalk lines, for each addition.) **FIGURE 1**

Use Chalk Lines or any other means

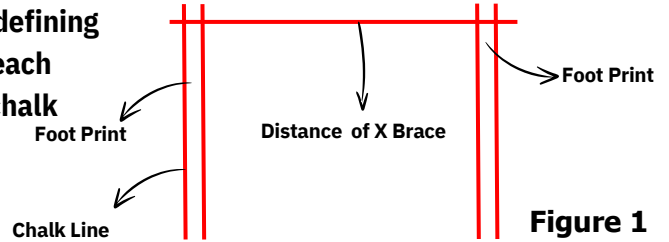

Figure 1

STEP 3

Lay out the starter bay on the floor, consisting of two columns, the required bases, and the required arms.

STEP 4

Connect the cantilever rack base to the column using the hardware supplied with your cantilever rack system. **FIGURE 2**

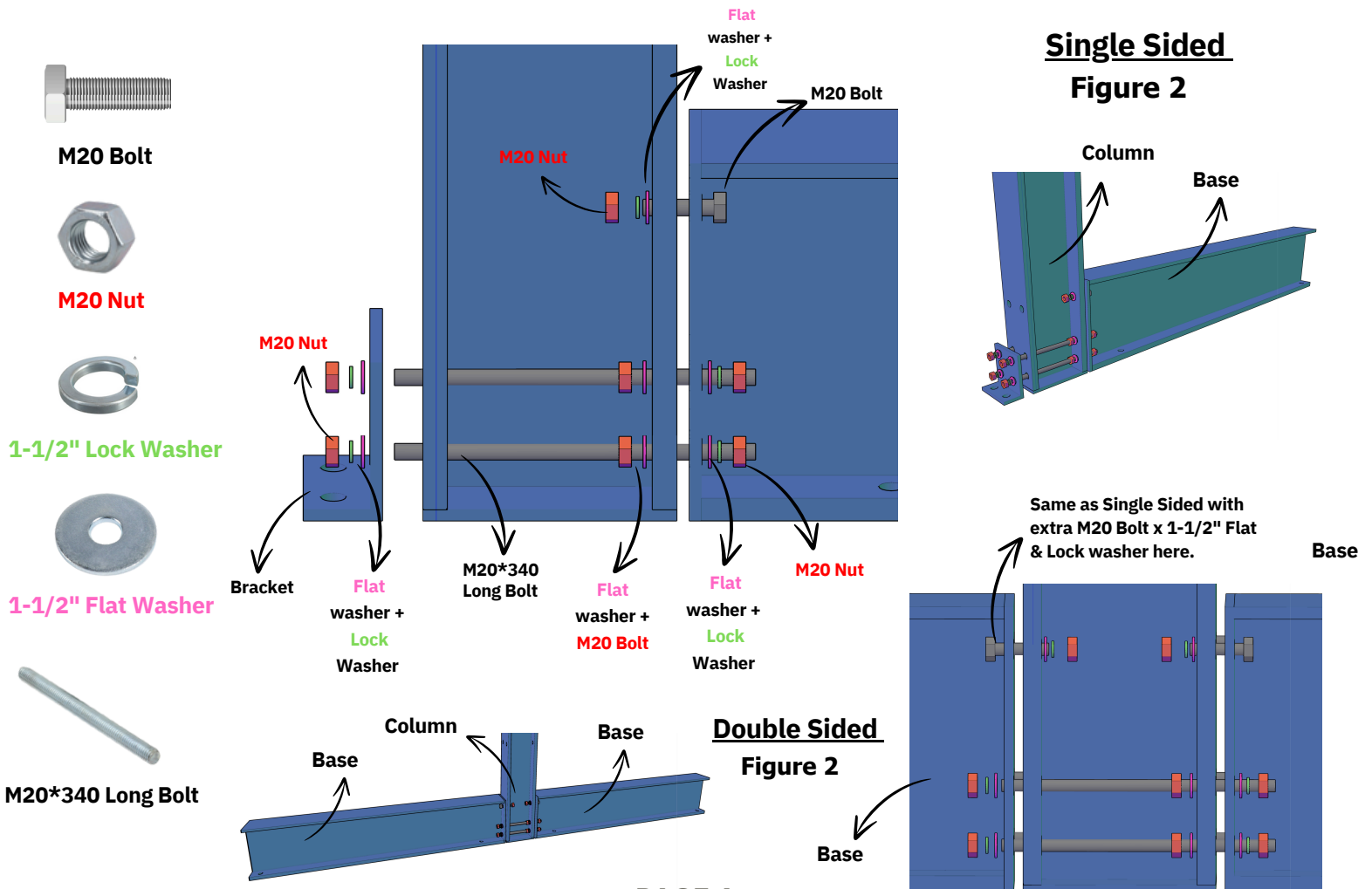

STEP 5

Install the wedge anchors into the cement floor with the hardware provided. **FIGURE 3**

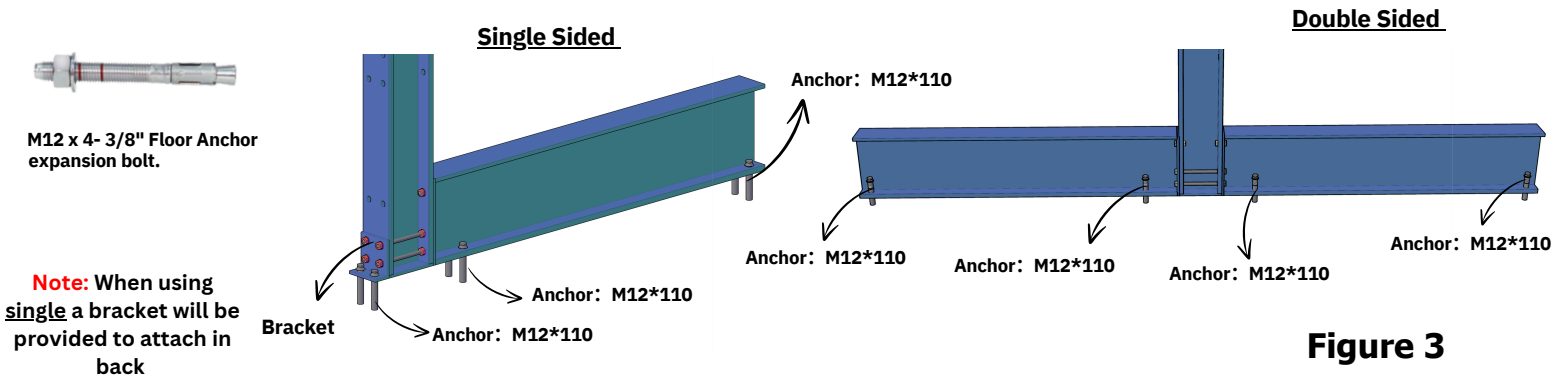

Cantilever Rack

Arms Layout

STEP 6

There are typically 4 bolts required per arm. Use the supplied hardware to connect the arms to your upright. Arm may be C-Channel, I-Beam or angle and hole patterns may vary. **FIGURE 4**

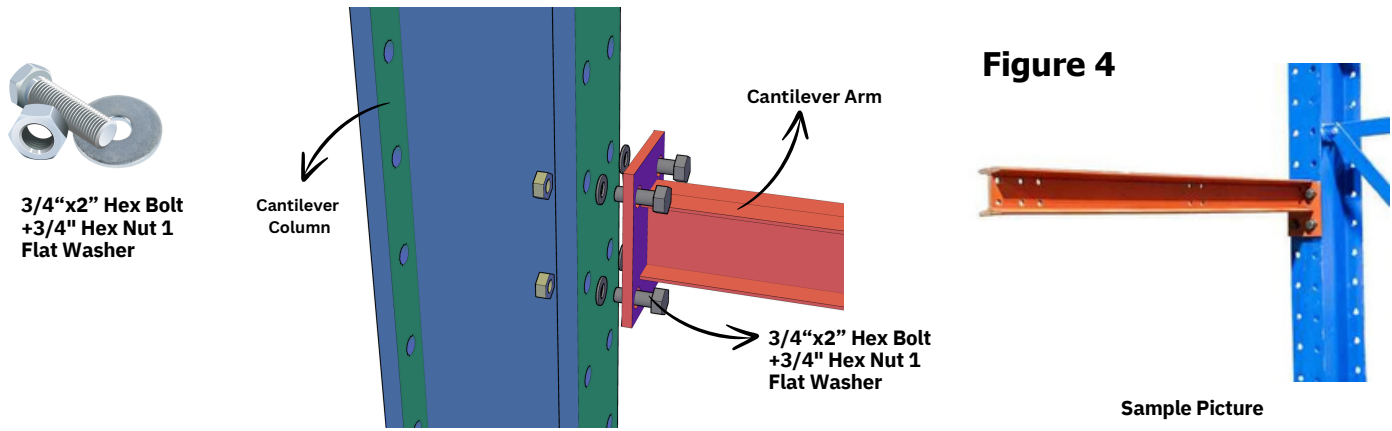

STEP 7

If you are using pipe stops or arm lips, attach them to the front of the arm using the hardware provided. -it may come welded in place if so specified.

STEP 8

Following steps 3 through 6, erect the second column of your cantilever rack system by securing the base to the column, installing the arms and any additional arm accessories. **FIGURE 5**

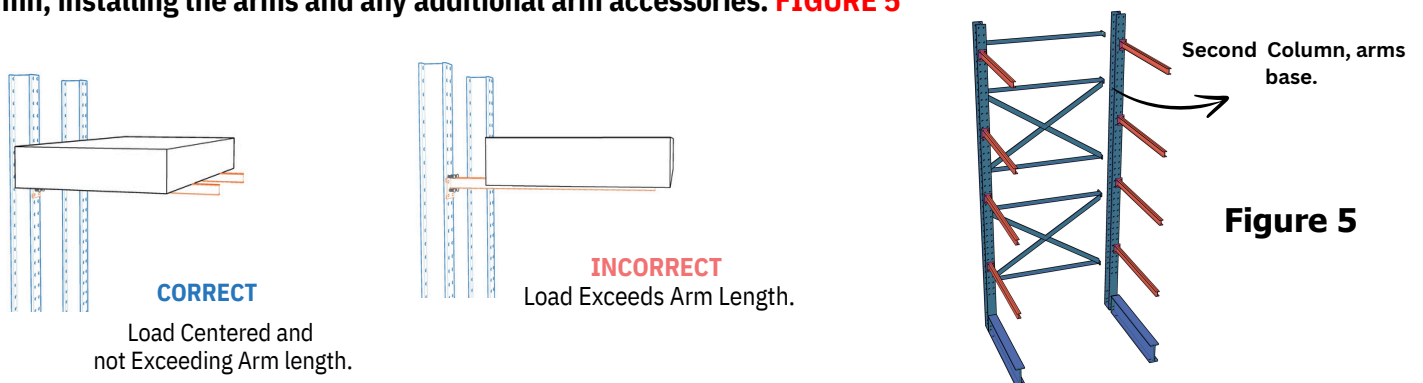

Cantilever Rack

X-Brace Layout

Installation The X-Bracing

Before start of Step 1 the X-Brace needs to be assembled.



There are designated holes on the column for the X-Braces and horizontal if needed.

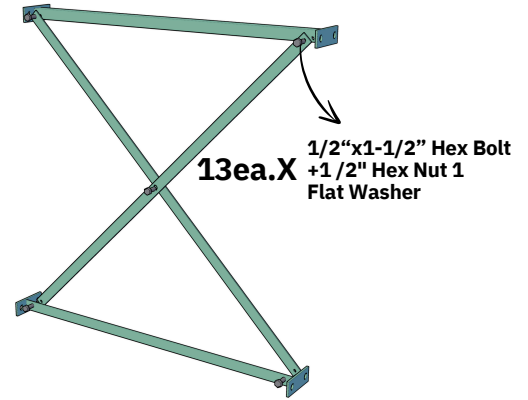
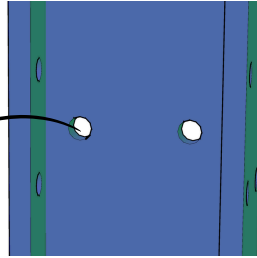

STEP 1

Once both columns and the arms are built, connect the bracing to the back of your cantilever rack system using the hardware provided by the manufacturer. Structural connectors need to be tightened to the snug-tight condition, which can be attained by a few impacts from an impact wrench or the full effort of a worker with an ordinary wrench that brings the connected plies into firm contact. **FIGURE 6**



Sample Picture

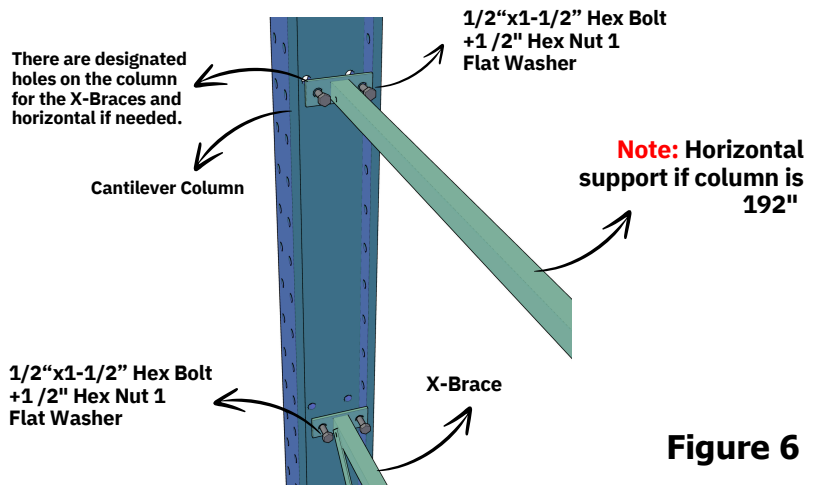

Figure 6

STEP 2

Using the instructions outlined in steps 1 through 8, continue to erect and build add-On bays to supplement your starter bays until the ideal rack system and footprint are achieved

STEP 3

Following steps 3 through 6, erect the second column of your cantilever rack system by securing the base to the column, installing the arms and any additional arm accessories. **FIGURE 8**

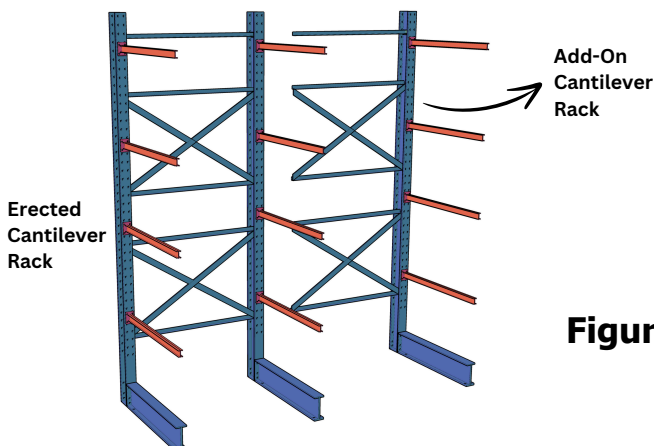

Figure 8